



FLAT VISION *Star 200*

60 kg / 132 lbs



15 kg / 33 lbs



32" → 60"
82 → 152 cm

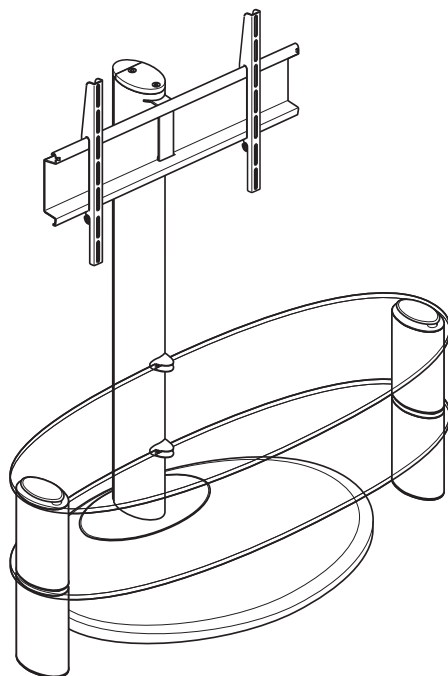

Qualità certificata
Certified quality

I ISTRUZIONI DI MONTAGGIO
GB MOUNTING INSTRUCTIONS
D MONTAGEANLEITUNG
F INSTRUCTIONS DE MONTAGE
NL MONTAGEVOORSCHRIFT

E GUÍA DE MONTAJE
P INSTRUÇÕES DE MONTAGEM
PL INSTRUKCJA MONTAŻU
CZ NÁVOD K MONTÁŽI
RUS ИНСТРУКЦИИ ПО УСТАНОВКЕ

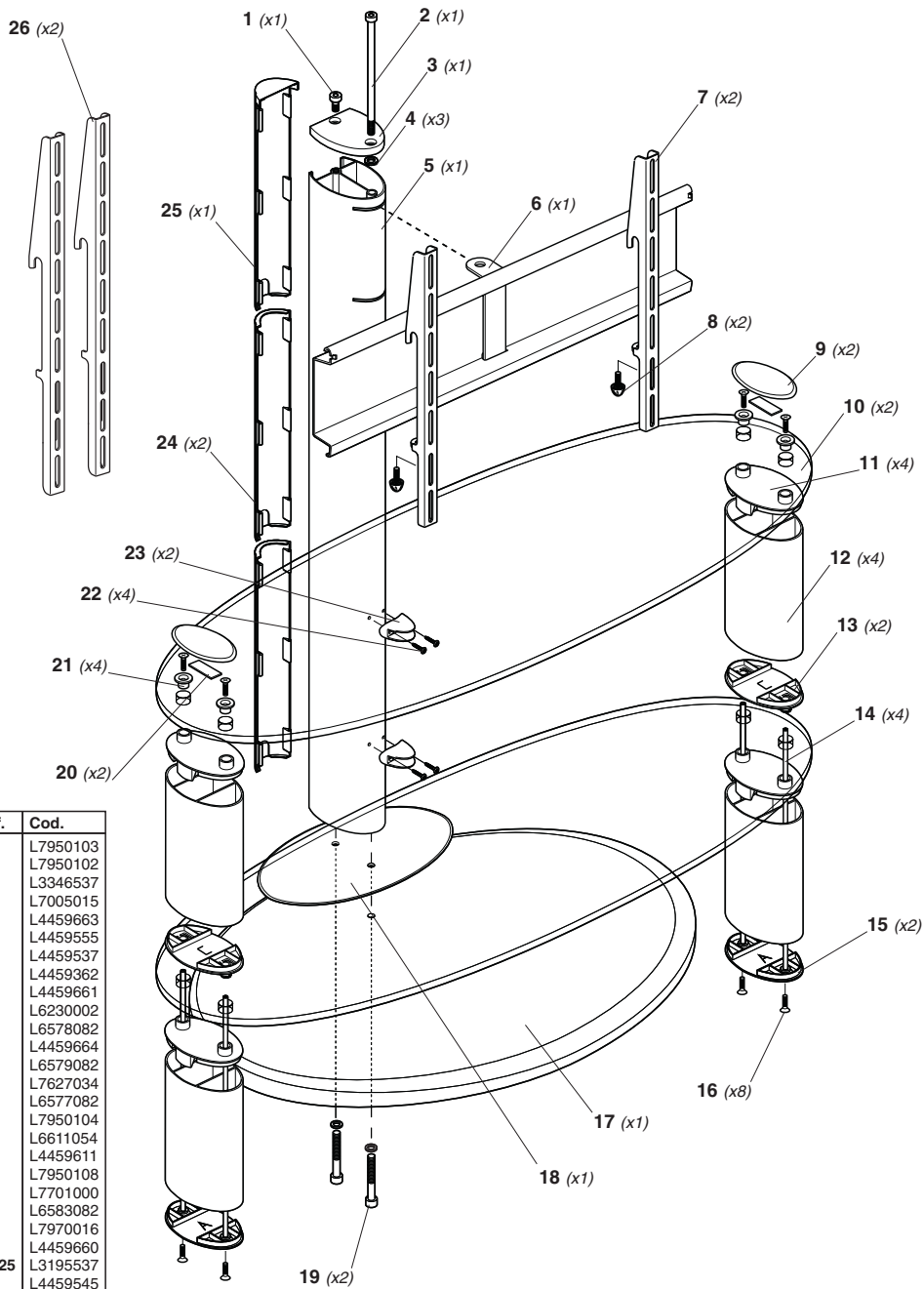

Ref.	Cod.
1	L7950103
2	L7950102
3	L3346537
4	L7005015
5	L4459663
6	L4459555
7	L4459537
8	L4459362
9	L4459661
10	L6230002
11	L6578082
12	L4459664
13	L6579082
14	L7627034
15	L6577082
16	L7950104
17	L6611054
18	L4459611
19	L7950108
20	L7701000
21	L6583082
22	L7970016
23	L4459660
24-25	L3195537
26	L4459545

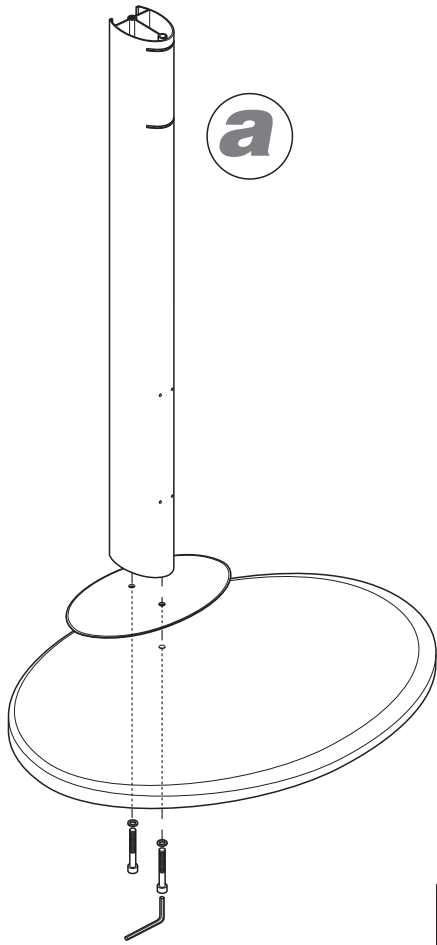

a

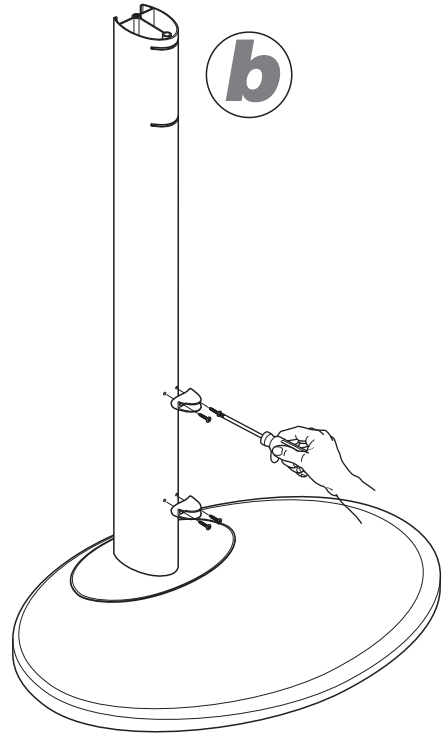

b

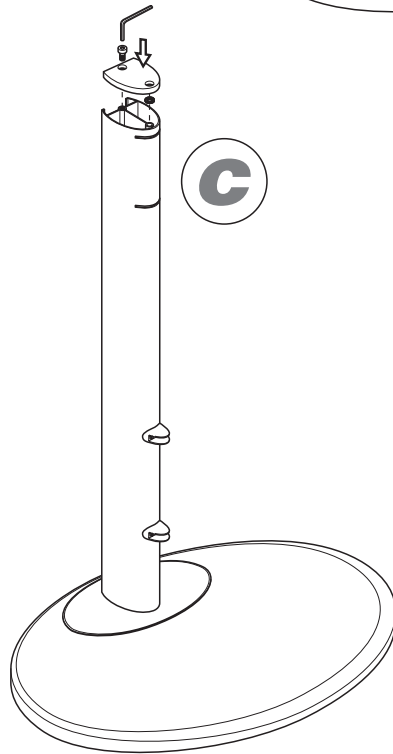

c

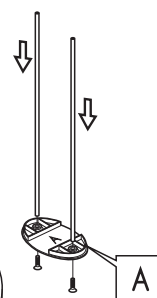
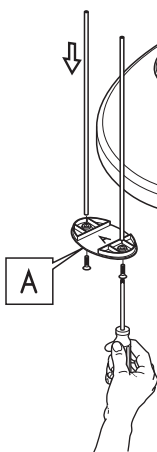
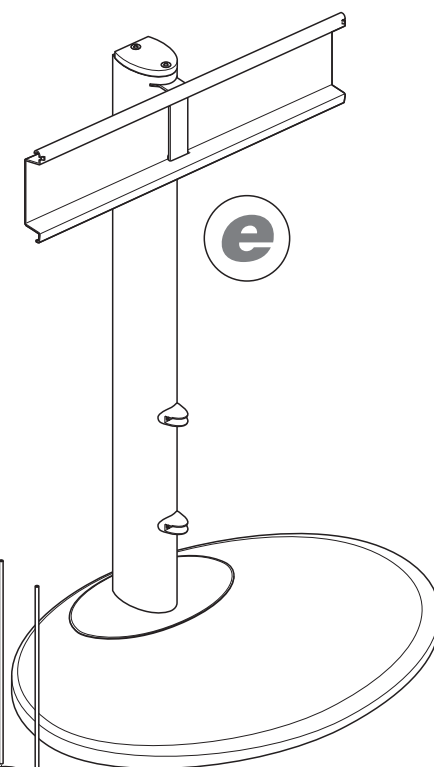
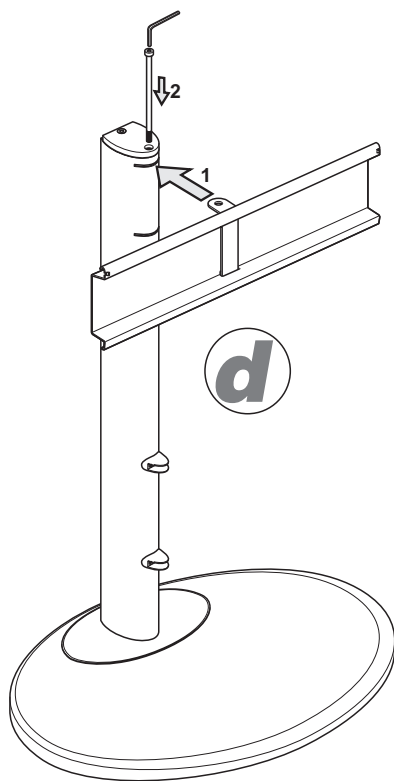

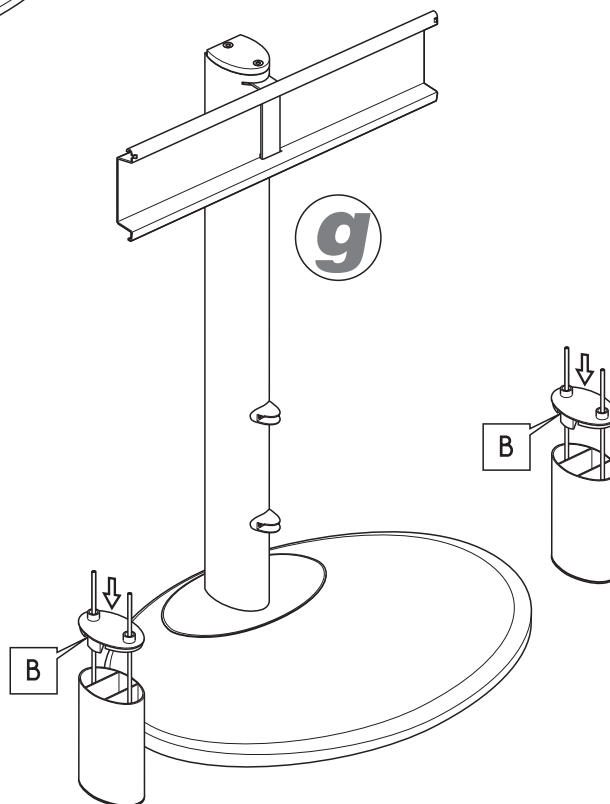
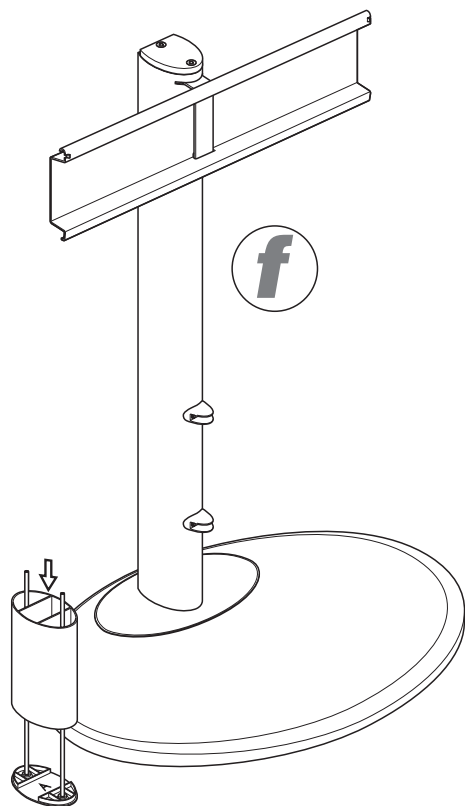

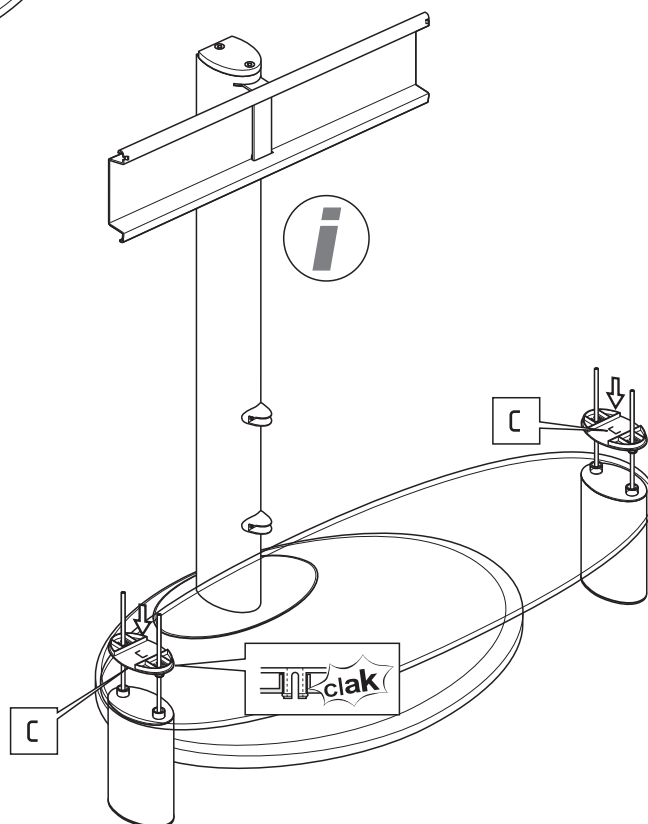
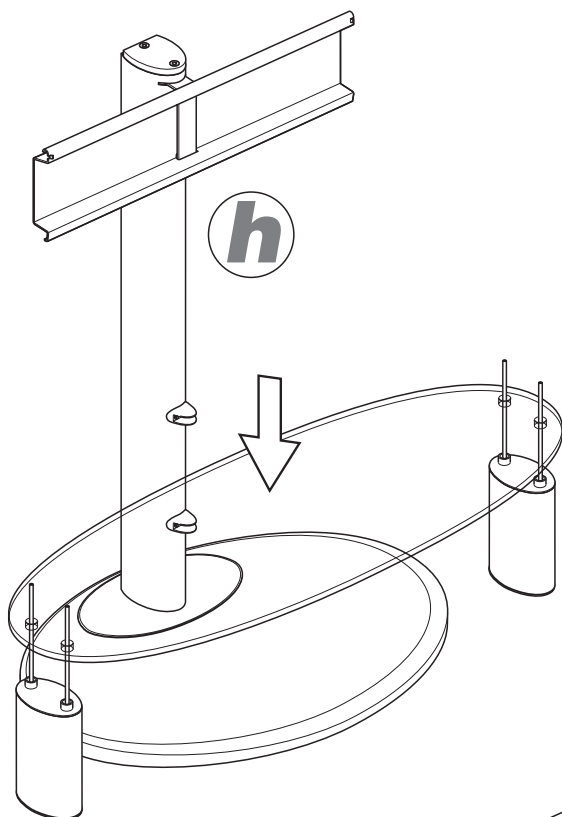
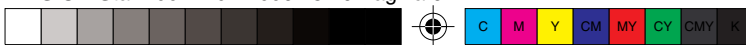

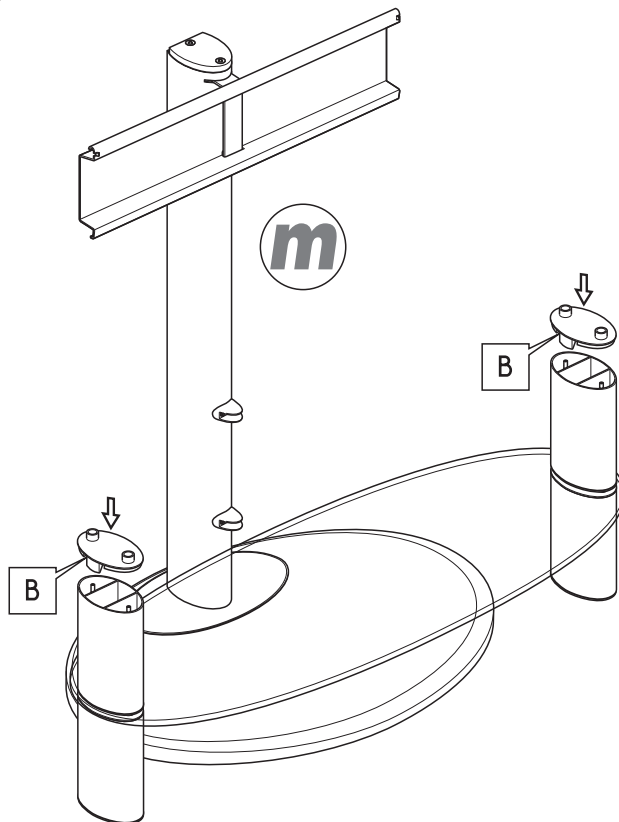
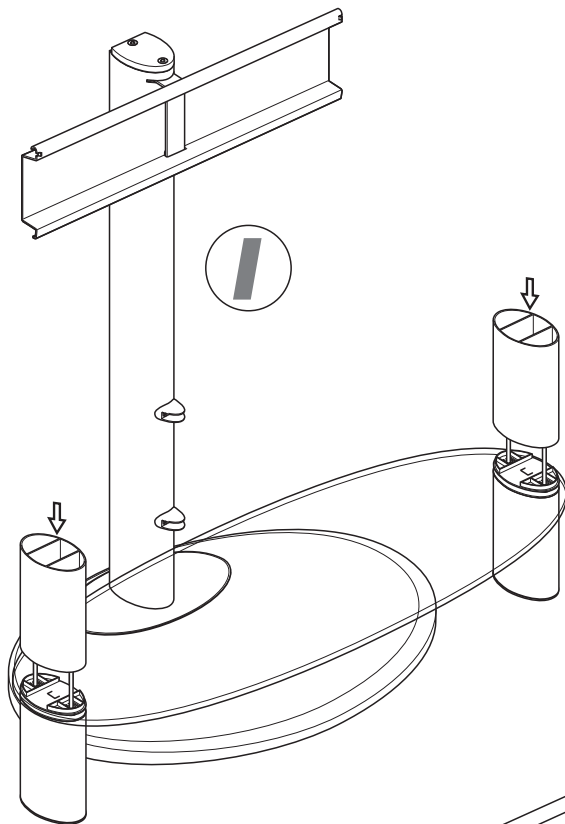

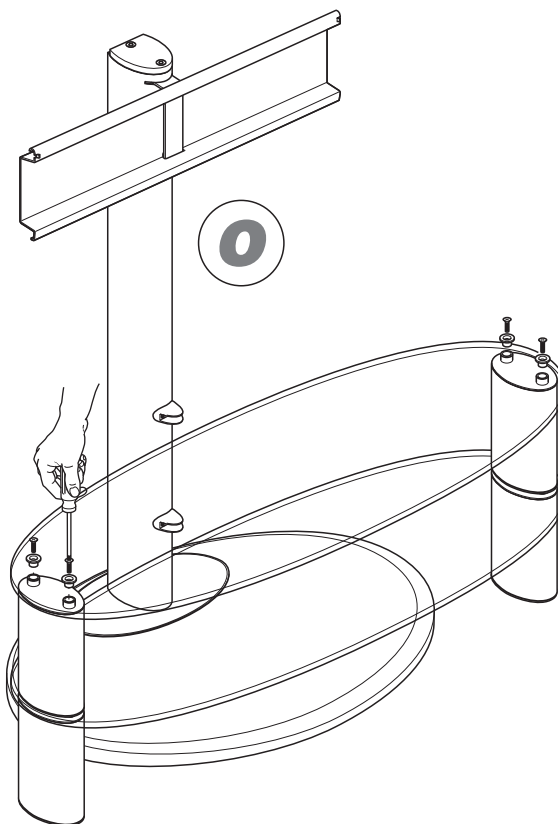
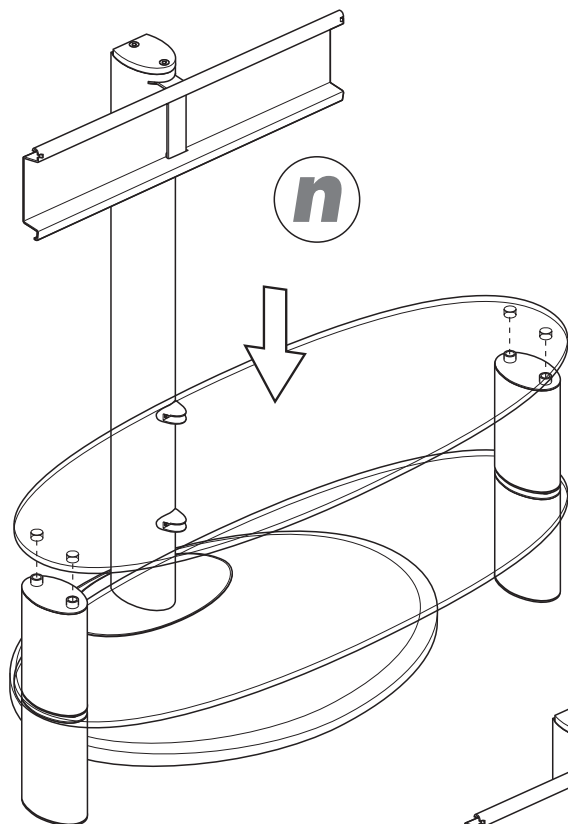

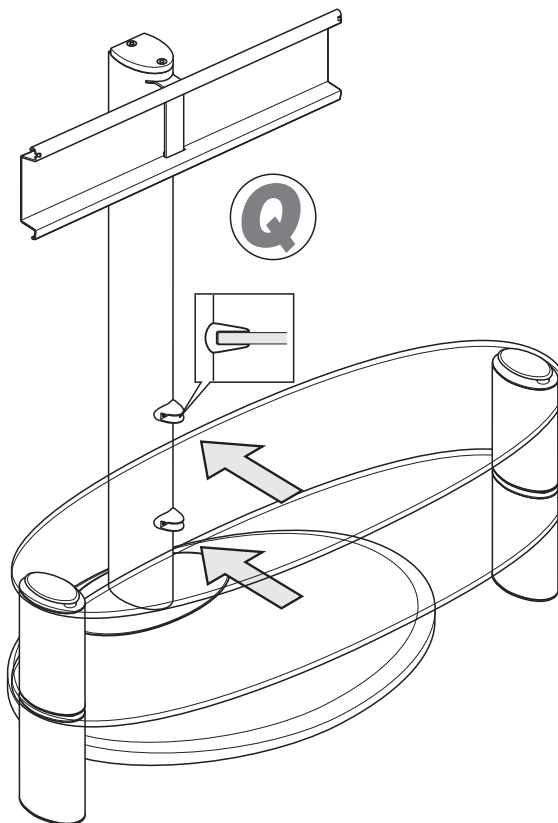
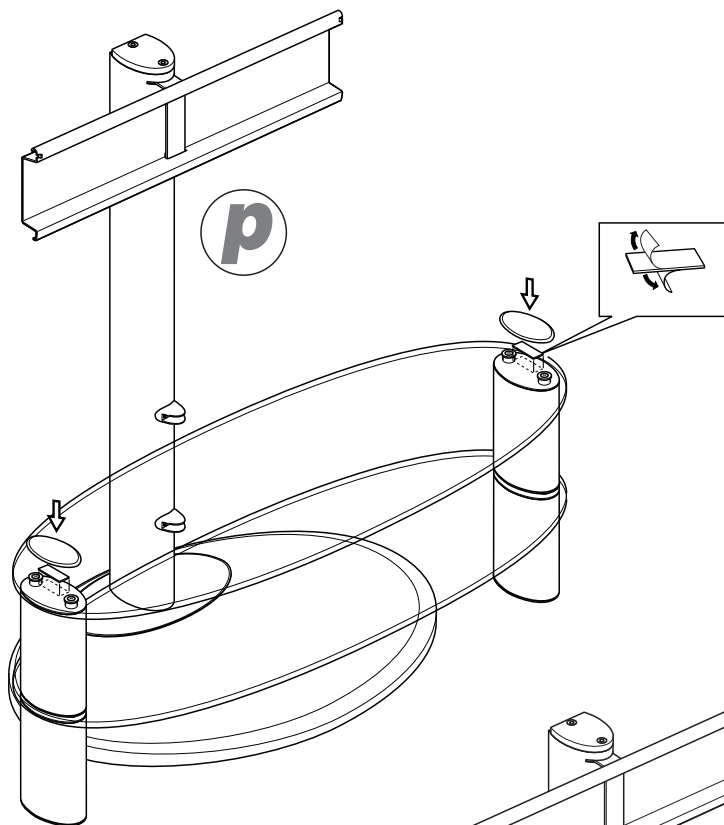

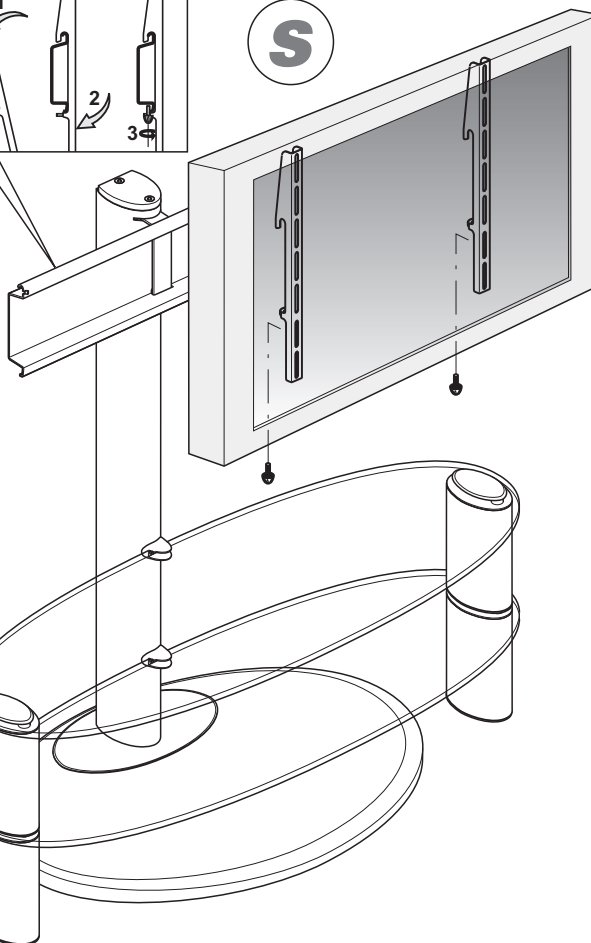
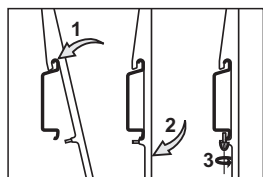
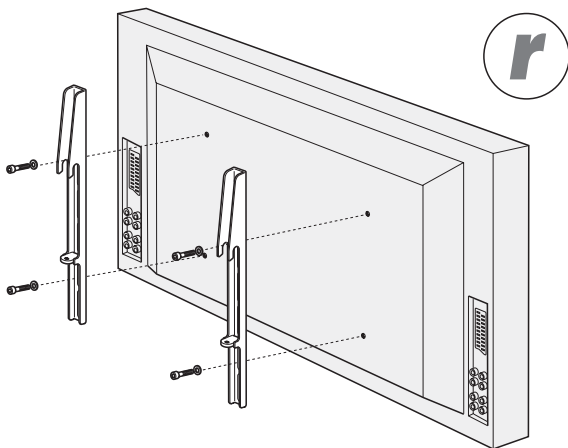

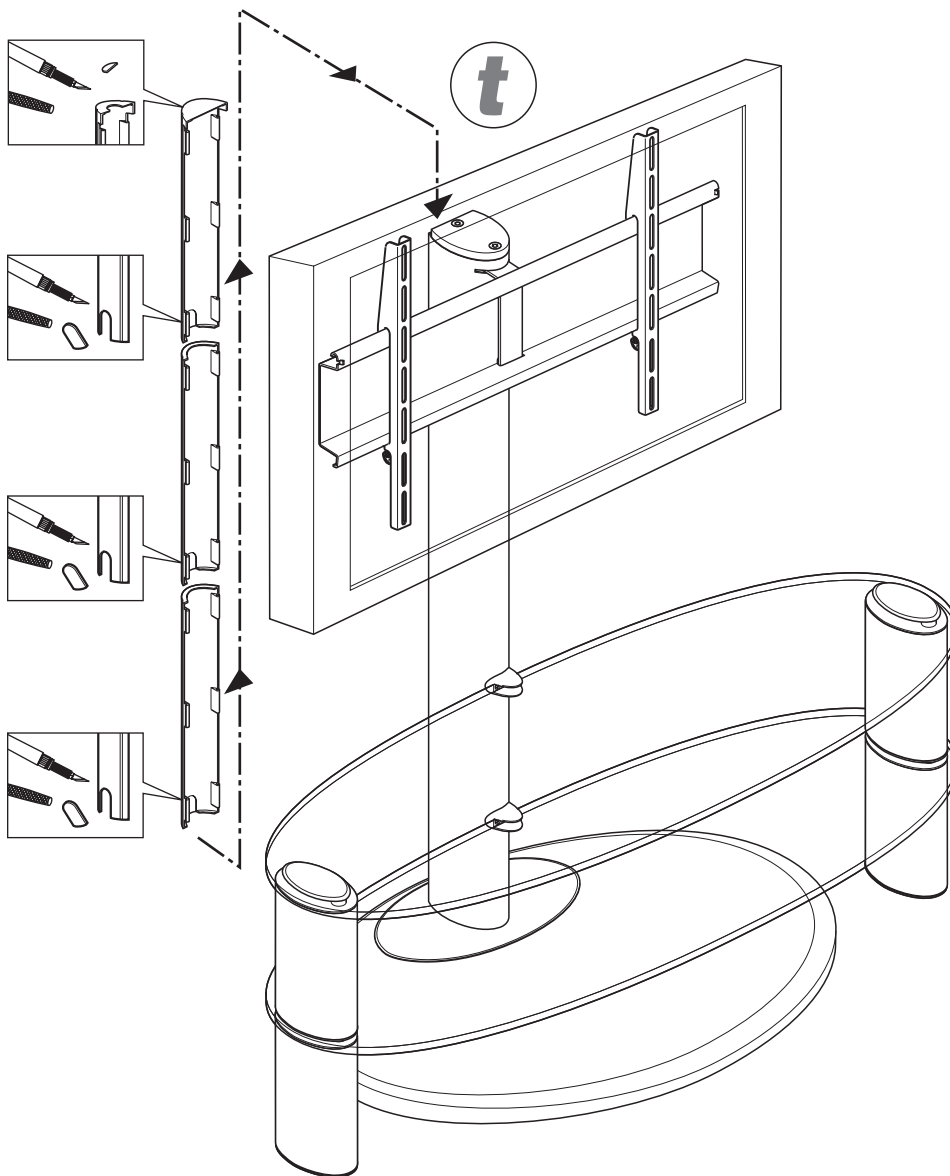



I Attenersi alle istruzioni di assemblaggio del manuale d'istruzioni. Si declina qualsiasi responsabilità in caso di mancata osservanza di queste istruzioni. Se necessario, si consiglia di rivolgersi ad un installatore professionista. **MANUTENZIONE:** Per la pulizia, usate una soluzione tiepida di acqua e sapone, **SENZA** solventi. Si consiglia di verificare periodicamente le condizioni del fissaggio e degli eventuali snodi. Il supporto é certificato per sostenere gli apparecchi nelle condizioni di peso e di fissaggio previste. Non idoneo ad ambienti esterni.

GB Carefully read and follow the assembly instructions provided. No claim can be accepted by the producer, concerning damages resulting from careless installation. When in doubt, consult a professional installer. **MAINTENANCE:** For cleaning use lukewarm soapy water and NO solvents. It is recommended to check periodically the conditions of the wall fixing and joints (if any). The support is designed and certified to safely carry appliances under the specified weight limits and fastening cautions. Not suitable for outdoor use.

D Bitte die Montage-Einleitungen genau beachten. Bei Nichtbeachtung dieser Anweisungen lehnen wir jegliche Verantwortung oder Haftung ab. Falls notwendig empfehlen wir die Inanspruchnahme einer geeigneten Fachkraft. **WARTUNG:** Zum Reinigen KEINE Lösungsmittel, sondern lauwarmer Seifenlauge verwenden. Es wird empfohlen, die Befestigung und die eventuellen Gelenke regelmäßig zu kontrollieren. Der Halter ist für Geräte unter den vorgesehenen Gewichts und Befestigungsbedingungen zertifiziert. Nicht für den Außenbereich geeignet.

F Suivez les instructions de pose contenues dans la notice de montage. Nous déclinons toutes responsabilités en cas de non observation de ces instructions. En cas de besoin, nous vous recommandons de faire appel à un spécialiste pour l'installation du support. **ENTRETIEN:** Pour le nettoyage ne PAS utiliser de solvants. Utiliser de l'eau savonneuse tiède. Nous conseillons de vérifier périodiquement les conditions de fixation et les articulations éventuelles. Le support est certifié pour soutenir les postes de télévision en respectant les poids et les conditions de fixation prévues. Ne pas utiliser à l'extérieur.

NL Lees voor het monteren het meegeleverde installatievoorschrift zorgvuldig door. Schade Claims ten gevolge van onzorgvuldige installatie kunnen door de fabrikant niet worden geaccepteerd. Bij twijfel m.b.t. de installatie, raadpleeg uw vakhandelaar. **ONDERHOUD:** Gebruik bij het schoonmaken lauw sopje, GEEN oplosmiddelen. Er wordt geadviseerd om van tijd tot tijd de toestand van de bevestiging en eventuele scharnieren te controleren. De standaard is gecertificeerd om de apparatuur in de voorgeschreven gewichts en bevestigingstoestand te ondersteunen. Niet geschikt voor gebruik buitenshuis.

E Atenerse a las instrucciones de montaje del manual de instrucciones. Se declina cualquier responsabilidad en caso de falta de cumplimiento de estas instrucciones. Si es necesario, se aconseja dirigirse a un instalador profesional. **MANTENIMIENTO:** Para la limpieza use agua de jabón tibia, NINGÚN disolvente. Es oportuno verificar periódicamente las condiciones del dispositivo de sujeción y de las eventuales articulaciones. El soporte está certificado para sostener los aparatos en las condiciones de peso y de sujeción previstas. No utilizar en el exterior.

P Siga as instruções de montagem contidas nestas indicações, declinamos toda responsabilidade em caso de acidente ou da não observação destas instruções, se for preciso, recomendamos, ajuda dum especialista para a instalação. **MANUTENÇÃO:** para a limpeza não utilize dissolventes. Utilize somente água morna com sabão. Aconselhamos verificar periodicamente as condições de fixação e das eventuais articulações. O suporte foi certificado para sustentar aparelhos dentro das condições de peso e fixação prevista. Não utilizar no exterior.

PL Wykonać montaż zgodnie ze wskazówkami podanymi w załączonej instrukcji użycia. Producent nie ponosi żadnej odpowiedzialności w przypadku nieprzestrzegania powyższych instrukcji. W razie konieczności, doradzamy zwrócić się do zawodowego instalatora. **CZYSZCZENIE:** stosować wyłącznie wodę i mydło. Zabronione jest używanie rozpuszczalników. Zaleca się regularne sprawdzanie poprawności zamocowania uchwytu do ściany, stanu połączeń elementów ruchomych (śruby, nakrętki). Uchwyt został zaprojektowany i przetestowany w ten sposób, aby przy właściwym zamocowaniu, bezpiecznie utrzymywał ciężar wydrukowany na opakowaniu.

CZ Postupujte podle pokynů k montáži uvedených v návodu k použití. Odmítáme jakoukoli odpovědnost, pokud byste se těmito pokyny neřídili. Pokud je to nutné, doporučujeme vám, abyste se obrátili na profesionálního technika. **ÚDRŽBA:** K čištění používejte vlažný roztok vody a saponátu, BEZ ředidel. Doporučujeme, abyste pravidelně ověřovali stav upevnění a příslušných spojů. Podpěra je certifikována pro uložení přístroje do určené hmotnosti a při správném upevnění. Není vhodná pro montáž do venkovního prostředí.

RUS Придерживаться инструкций по установке, содержащихся в руководстве по эксплуатации. При несоблюдении данных инструкций любая ответственность отклоняется. При необходимости рекомендуем обратиться к профессиональному установщику. **ОБСЛУЖИВАНИЕ** Для чистки использовать теплую мыльную воду, БЕЗ растворителей. Рекомендуется периодически проверять состояние крепления и возможных шарнирных соединений. Опора сертифицирована для держивания аппаратуры определенного веса в определенных условиях. НЕ использовать НА УЛИЦЕ.

PRINTED 05/06
M9993297



MELICONI S.p.A. - Via Minghetti, 8/10 - 40057 CADRIANO DI GRANAROLO EMILIA - BOLOGNA - ITALY
www.meliconi.com - info@meliconi.com